

Hewitt Technologies Inc. – Hewitt-Tech.com

Gen-II 3V Secondary Air Injection System Bypass Kit

05-06 Tundra, 05-07 Sequoia, 05-09 4Runner-GX470-LX-LC.

4.7L Installation Instructions



Introduction:

Before installing the bypass kit, it is highly recommended to address codes not related to the SAIS. For the Gen-II kit to work properly, the wiring, connectors, and engine control module (ECM) cannot be damaged. For pressure sensor circuit trouble codes, it is important to inspect the circuit wiring and make any necessary repairs. The related wiring is between the air switching valves, the air injection control drivers, and the ECM. Further troubleshooting, pressure sensor replacement or, in EXTREME cases, ECM replacement may be needed if there is damage or if the vehicle has been driven for an extended period with circuit fault codes.

The Gen-II unit emulates operation of the SAIS by replacing the factory air injection control driver (AID). For this application, the unit will also connect to the vacuum switching valve (VSV) connections on the passenger side of the intake manifold and tap into the system's pressure sensor circuit at the ECM. Unless the intake manifold is removed, there is no other way to make these connections or to make this a 100% plug-and-play kit on these vehicles. With the Gen-II unit and block off plates installed, the rest of the system, except for the pressure sensor underneath the intake manifold, may be removed. Regardless of the bypass kit or SAIS, the vehicle still requires the pressure sensor as it is still utilized by the ECM. If your pressure sensor is damaged (rare on these vehicles except for rodents chewing on wires), a new pressure sensor can be wired in at the ECM the same as where the unit taps in to prevent having to remove the intake manifold. If you have questions about the installation or use of this kit, please visit us at www.Hewitt-Tech.com to view our Trouble Codes and FAQ pages. You can also contact us directly using the information found on the "Contact Us" page.

You can also view our installation videos on our YouTube channel by searching "Hewitt-Tech". If you're viewing these instructions electronically, click [Hewitt Tech YouTube Channel](#). If you have questions about any part of the installation, kits, or your codes, please call us toll-free at [1-844-307-7671](tel:1-844-307-7671) or email us at support@hewitt-tech.com.

Important: It is illegal to remove, dismantle, or otherwise cause to be inoperative any pollution control device required by federal, state, or local emissions law. The Gen-II bypass kits are sold for off-road or competition use only, no other applications are intended or implied. By installing or using this SAIS bypass kit, the vehicle owner and/or installer acknowledges and assumes ALL risks associated with its installation and use.

Needed for Installation:

- #2 Phillips and flathead screwdrivers
- 8mm, 10mm and 12mm ratchets/wrenches/sockets/extensions
- Wire cutters/strippers
- 1-1.5 hours of labor



Installation Steps:

- 1) Open the hood and remove the engine cover(s). Vehicles like the GX470 and LX470 will have extra covers to the left and right of the engine that also need to be removed.
- 2) Disconnect the negative battery terminal. Leaving the battery disconnected while installing the bypass kit will clear all pending and active trouble codes as well as reset learned idle and fuel trims. For 2009 and newer vehicles permanent will still be scannable but no CEL should be on after. Those permanent trouble codes will clear automatically when the Gen-II kit completes its first run sequence.



Figure 1 – 2005 GX470 shown. All vehicles covered in these instructions have the same layout as shown.

- 3) Locate the air injection control driver (AID) on the inner driver-side fender. It is mounted to a bracket that is bolted to the fender. The AID is in the same location for all vehicles covered by these instructions but may be in a slightly different orientation or have a different bracket than the one shown.

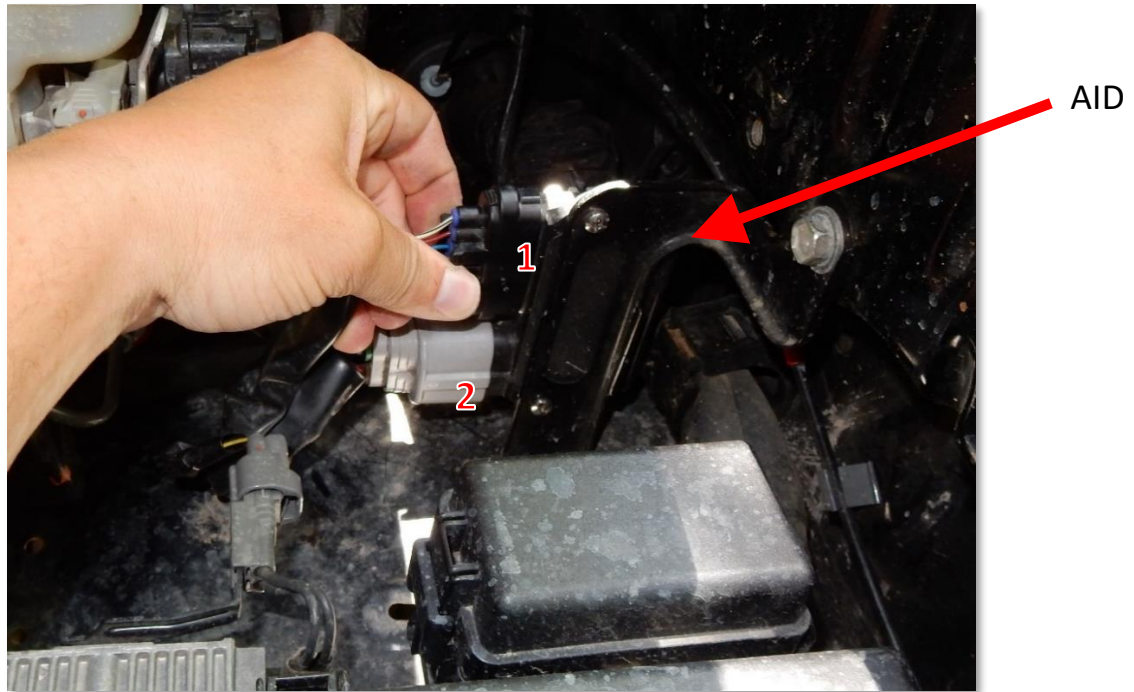

Figure 2 - Disconnect the Factory AID Connectors.

- 4) Figure 3 – Disconnect Connectors 1 & 2 from the AID. Disconnect both connectors from the air injection control driver (AID) on the inner driver-side fender.
- 5) Install the custom plug cap into the large two-wire connector and tuck it out of the way. This disconnects +Batt supply and the air pump motor.



Figure 3 – Install Custom plug cap into connector.

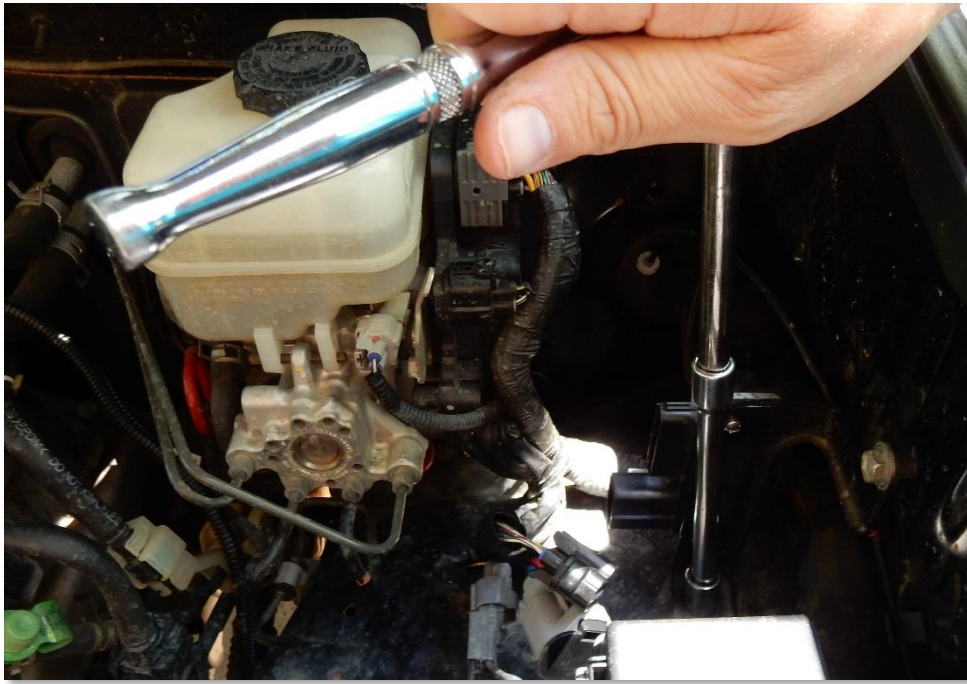

Figure 4 - Remove the AID Bracket.

- 6) Remove the AID bracket from the fender. Next, remove the AID from the bracket and set it aside since it is no longer needed. The bracket and AID may be mounted slightly differently on your vehicle than what is shown.



Figure 5 - Removing the AID from the Bracket.



Figure 6 – Mount Gen-II Unit to sub-bracket.

- 7) Use the the included stainless steel hardware to mount the Gen-II unit to the bracket. Be careful not to pinch the Gen-II wires against the bracket when mounting the bracket back in place.
- 8) Connect the black factory AID harness and the Gen-II harness to the Gen-II unit. Tuck or zip-tie the large capped-off connectors out of the way.
- 9) Connect the Gen-II harness to the remaining connector of the Gen-II unit.

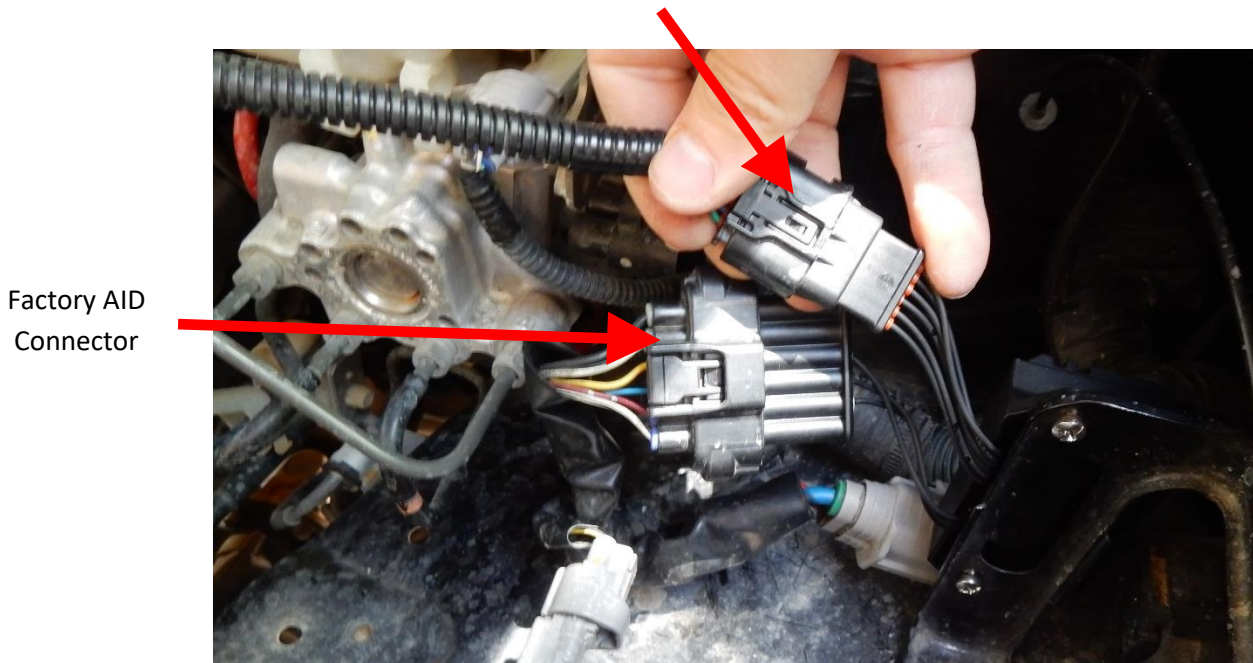
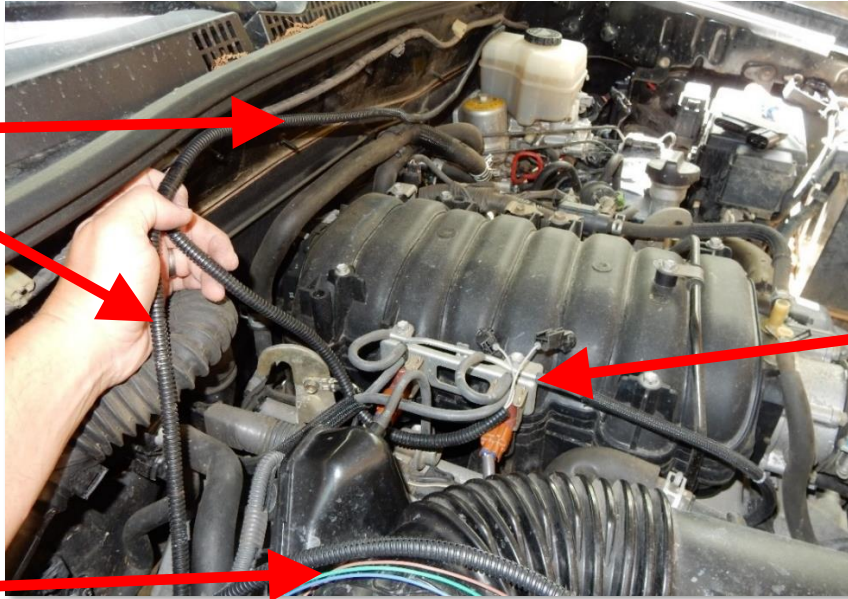

Figure 7 – Gen-II unit and connecting the AID connectors.

Route the Gen-II Harness



VSVs and Gen-II Connectors

Three wires of Gen-II Harness to Pass through Firewall to the ECM.

Figure 8 – Route the Gen-II Harness Across Firewall.

- 10) Route the Gen-II harness around the brake expert cylinder and along the firewall toward the passenger-side corner of the engine compartment.
- 11) Route the Vacuum Switching Valve (VSV) part of the harness to the VSV location on the top passenger side of the intake manifold.
- 12) Disconnect the two brown VSV connectors and plug the two mating Gen-II harness connectors into them. The connection order of black to brown connector does not matter, just plug them both in.

Factor ASV connector

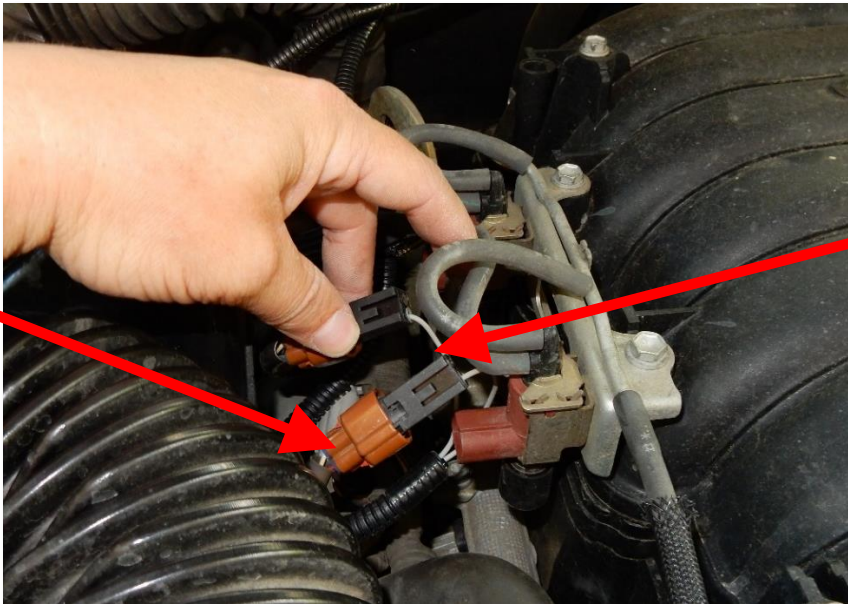

Gen-II harness Connectors.

Figure 9 - Disconnect Factory ASV Harnesses and Connect to Gen-II Connectors.

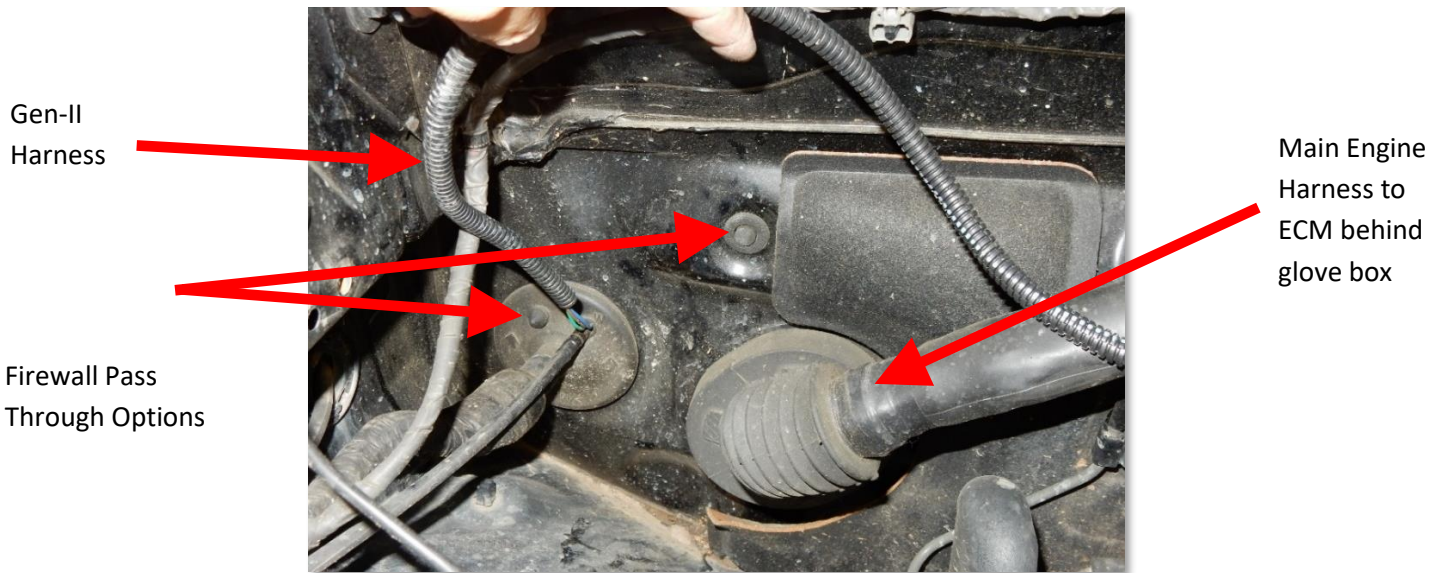

Figure 10 - Route End of Harness Through the Firewall for ECM Connections.

- 13) Route the three wires at the end of the harness to the passenger-side corner of the firewall. The three wires need to pass through the firewall to connect to the ECM wiring.
- 14) Push the wires through the seal for the body electrical harness. You can use an existing hole or create a new opening. There is also typically a rubber nipple whose end can be sniped off to create a new opening in the seal.
- 15) Starting at the Gen-II unit, secure the harness along the firewall using zip-ties toward where it passes through. Trim the excess wire loom for a custom fit and push through the remaining wire to finish the under-hood portion of the installation.



Figure 11 – Completed Under-Hood Gen-II Harness Installation.

16) Remove the glove box to gain access to the ECM and wiring. Take care when removing any trim pieces and clips so that you do not damage the dash pad as vehicles like the GX470 are known to have delicate dash pads. Once the glove box is removed, you will be able to pull the three harness wires through to complete the installation.

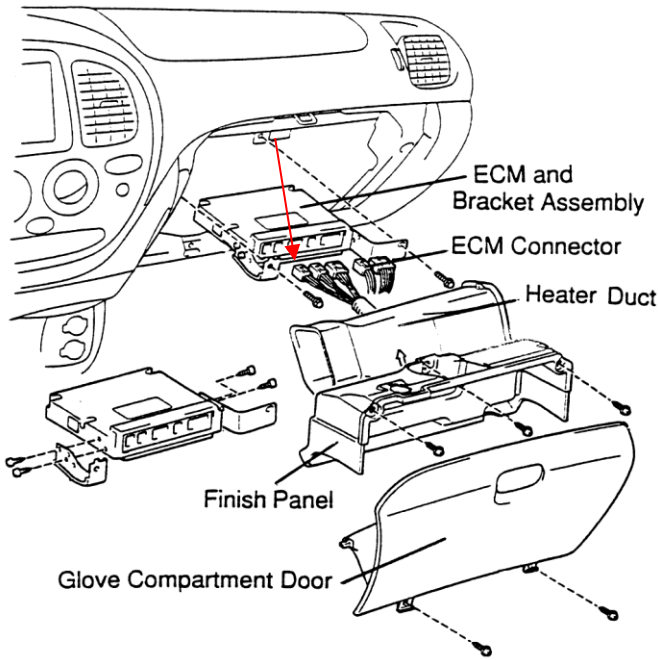

Figure 12 – ECM Access 05'-06' Tundra, 05'-07' Sequoia.

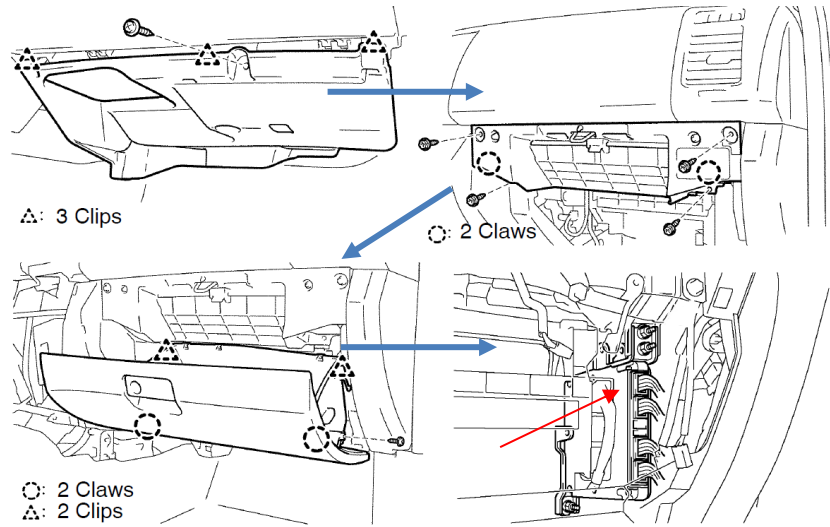

Figure 13 - ECM Access 05'-09' 4Runner.

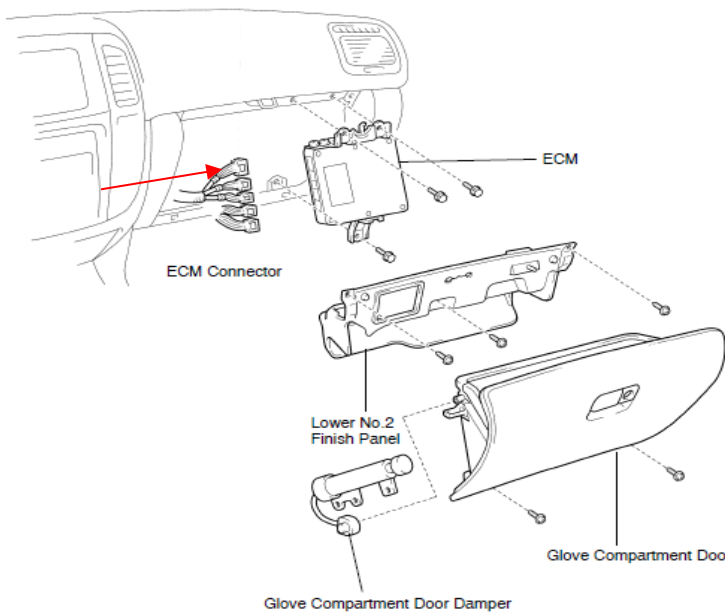

Figure 14 - ECM Access LX470, Landcruiser.

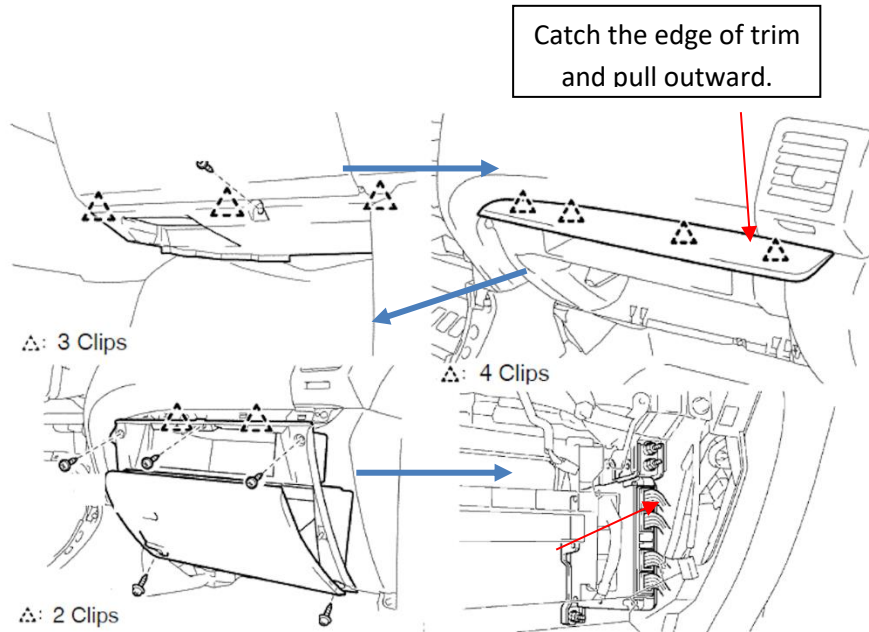

Figure 15 – ECM Access 05'-09' GX470.

Always at the Top or Furthest Left Depending on ECM Orientation in Vehicle.

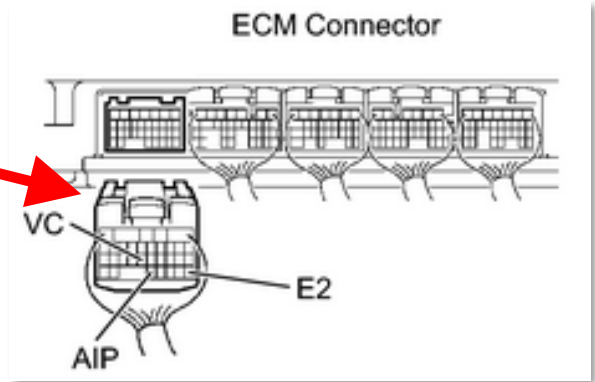
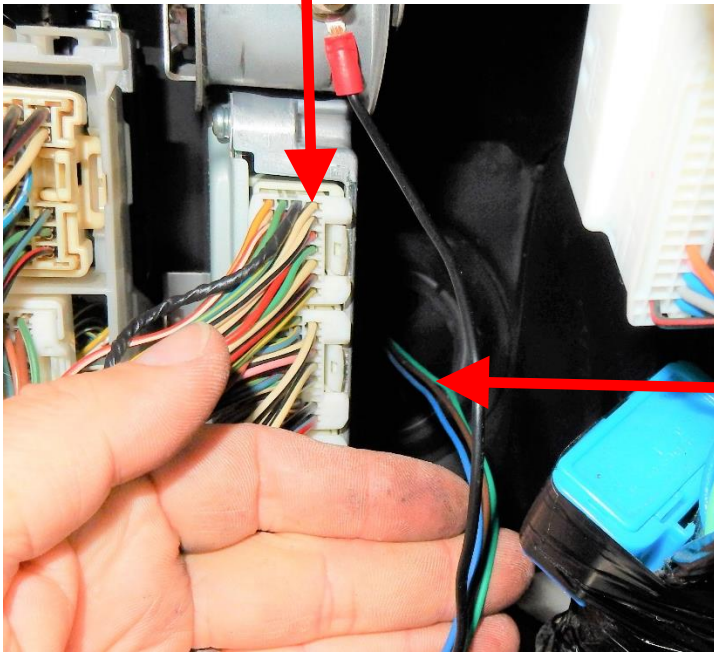

Figure 14 – Pressure Sensor Wires to Tap into.



Gen-II Harness Wires Entering the Cabin.

Figure 15 - Gen-II Harness Wires.

- 17) Once the glove box is removed, reach behind the ECM to where the three harness wires enter the cabin. Carefully pull any remaining slack in the wires into the cabin and route to the ECM wiring.
- 18) Disconnect the Top or Leftmost ECM Connector as the ECM is mounted. The small red arrows on Page 8 show the correct connector for each vehicle's ECM location.
- 19) Remove electrical tape and wire harness wrap from the harness bundle to allow better access to the individual wires of the connectors. Be extremely careful not to cut or break a wire when removing the harness protection.
- 20) The solid green, brown and blue wires of the Gen-II Harness will tap into the wires of pins 23, 28, and 32.

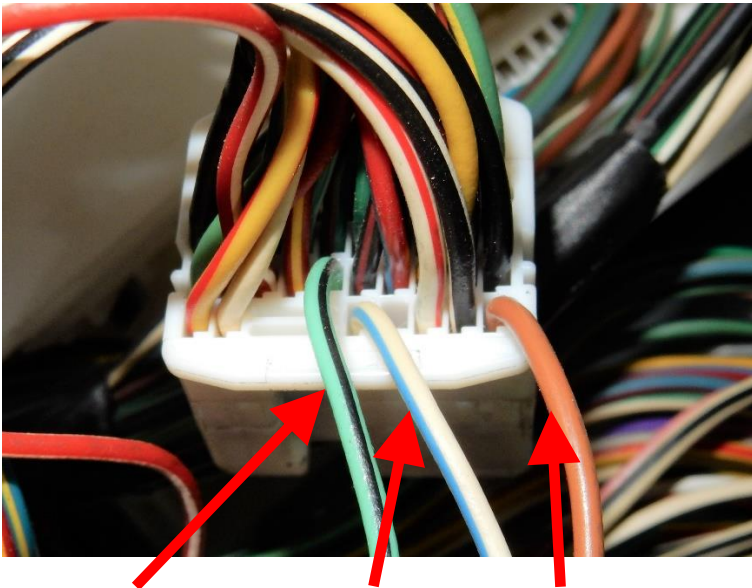

Pin 23 Pin 32 Pin 28

Figure 18 - GX470 Connector shown matches Figure 22 below.

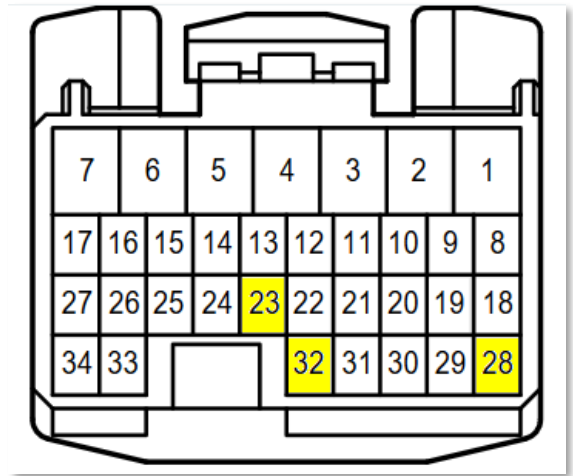

Figure 19 – Pin Numbers as the wires come out of the connector as shown in figure 18.

21) Use your Figures 20, 21, 22 or 23 for your vehicle to find and separate the pressure sensor wires from the rest of the connector’s wire bundle. **Triple-check that you have identified the correct ECM wires. If your vehicle’s wire colors do not match do not make any connections before making sure you are looking at the correct connector and pin numbers.**

22) Solder or use the included Scotchlok® connectors to tap into the factory wiring. **It is highly recommended to solder the Gen-II wires into the factory wires and to never cut the factory wires. Do not solder while the connector is plugged into the ECM. It is also important to trim off any extra wire before making the connections to the vehicle.**

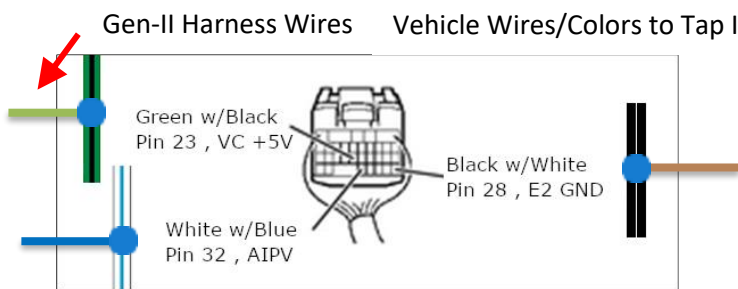

Figure 20 – 05’-06’ Tundra Wire Colors.

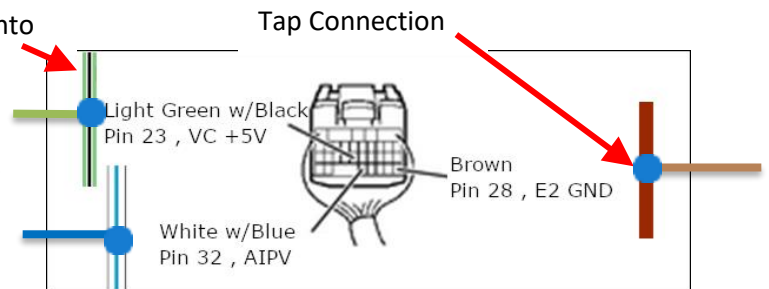

Figure 21 - GX470 Wire Colors (shown in Figure 19).

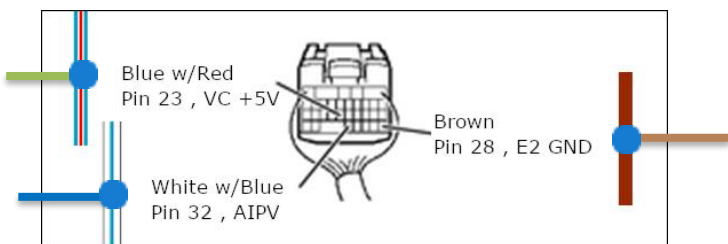

Figure 22 – Landcruiser, LX470 and 4Runner Wire Colors.

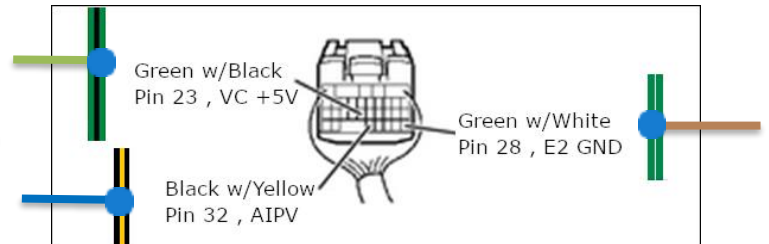

Figure 23 - Sequoia Wire Colors.

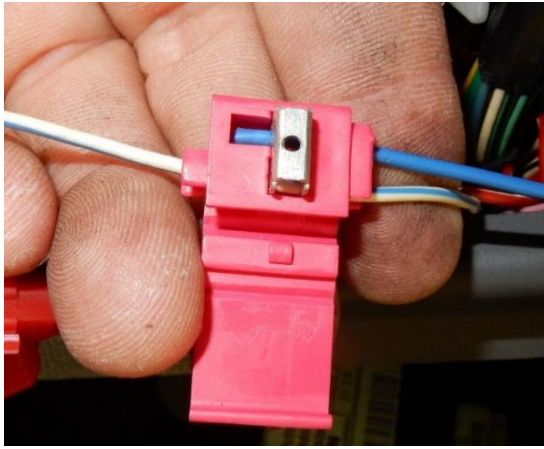

Figure 24 - Using Scotchlok® Connector.

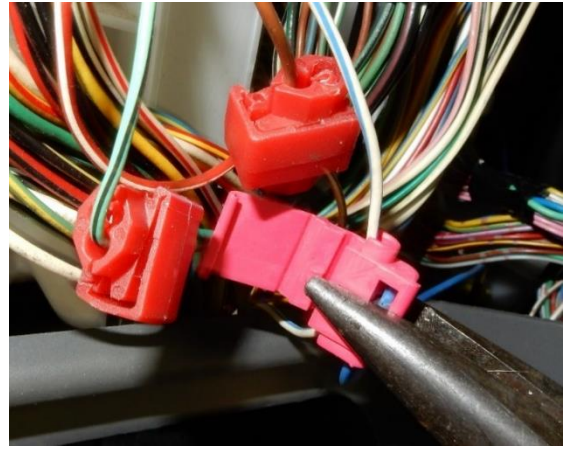

Figure 25 - Pressing Scotchlok® Blade onto Wires.

- 23) Trim off all extra Gen-II harness wire but leave enough you will not strain the wires or connection when plugged back into the ECM.
- 24) Stagger the connections along the harness to spread out the bulk of the connections. The bundle can be too tight when reconnected if they are all stacked in the same place.
- 25) Solder the Gen-II wires into the factory wires and insulate or use the Scotchlok® connectors to complete the connections.
- 26) To use the Scotchlok® connectors, slip the connector over the factory wire and snap the side closed. Insert the Gen-II wire until it bottoms out in the other opening. Hold the wires in the center of each opening and use a pair of pliers to firmly press the metal connector down into the plastic connector body until flush. Bend the cover over and snap it closed.
- 27) When you have finished all three tap connections, wrap the bundle as needed and plug the ECM connector back into the ECM.

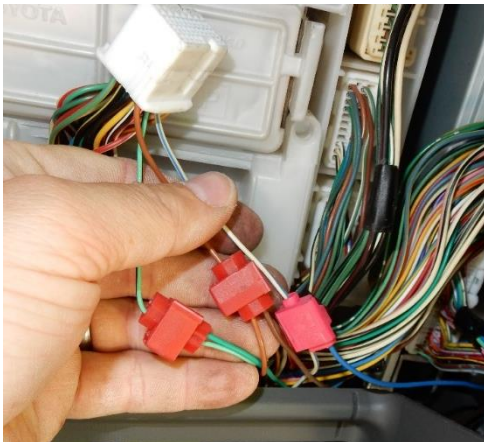

Figure 176 – Complete Connections Staggered Out.

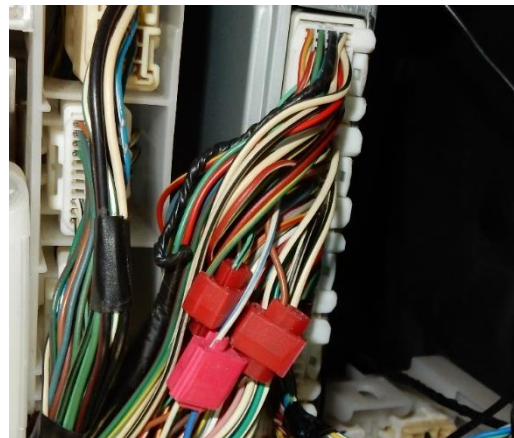

Figure 167 - Plug Connector Back into ECM.

- 28) Before reinstalling the glove box, reconnect the negative battery terminal. If the battery was not disconnected during installation, you will still need to clear the active and pending trouble codes by disconnecting the battery for at least 2 full minutes or by using an OBDII/scan tool.

Important: Disconnecting the negative battery terminal to reset the codes will also reset engine tuning parameters, such as fuel trims. It is completely normal for the engine to run rough, idle slow/fast, and even stall after the first start. Let the engine idle for 10 min for the computer to relearn the idle and fuel trims before driving.

- 29) Start the engine. At this point, there should be no active or pending codes for the secondary air injection system. The check engine light (CEL) should be off, assuming there are no other problems with the vehicle. If this is a 2009 or newer vehicle, permanent trouble will remain as scannable, but the CEL should still be off. Permanent trouble codes will automatically clear by themselves the next time the secondary air injection system is commanded to run, and the Gen-II unit completes its operation with no problems.
- 30) If the engine does not start after 3-4 attempts, STOP, and turn off the ignition. Carefully go over the connections again and make sure you are tapped into the correct factory wires; the connections are solid. If you still need help verifying the wiring and connections, please email us with large, detailed pictures like those in Figures 18, 24 and 23 that show all the wire colors and connections.
- 31) Once all the codes are clear and the CEL is off, finish the installation by re-installing the glove box and engine covers.
- 32) If not already installed, install the block off plates. Block off plate installation is covered in separate instructions.
- 33) Congratulations! You are finished with the installation and should never have a problem with the secondary air injection system again.

If you have questions or trouble before, during, or after installation,
Please contact us directly!

Toll-Free: [1-844-307-7671](tel:1-844-307-7671) | Email: support@hewitt-tech.com
<https://Hewitt-Tech.com>

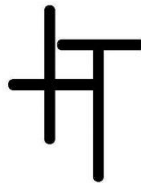

Important: It is illegal to remove, dismantle or otherwise cause to be inoperative any pollution control device required by federal, state, or local emissions law. The Gen-II bypass kits are sold for off-road or competition use only, no other applications are intended or implied. By installing or using this SAIS bypass kit, the vehicle owner and/or installer acknowledges and assumes ALL risks associated with its use.